

GUILBERT EXPRESS
Le Péripole - Lot 209 - 210
33, avenue du Maréchal de Lattre de Tassigny
F- 94127 FONTENAY SOUS BOIS CEDEX
Tel. +33(0) 825 800 251 - Fax +33(0) 825 800 238

DTP13E - Raptor	
Created on	10/01/2012
Modified on	26/04/2019
Issue	R

Cat. No.:	1001 - 1027 - 1029 - 1030 - 1045 - 1070 - 1090 - 1150 - 1160
Name	RAPTOR

Product: Handles, torches
Activity: Roofing, industry
Users: Professional
Energy: Propane

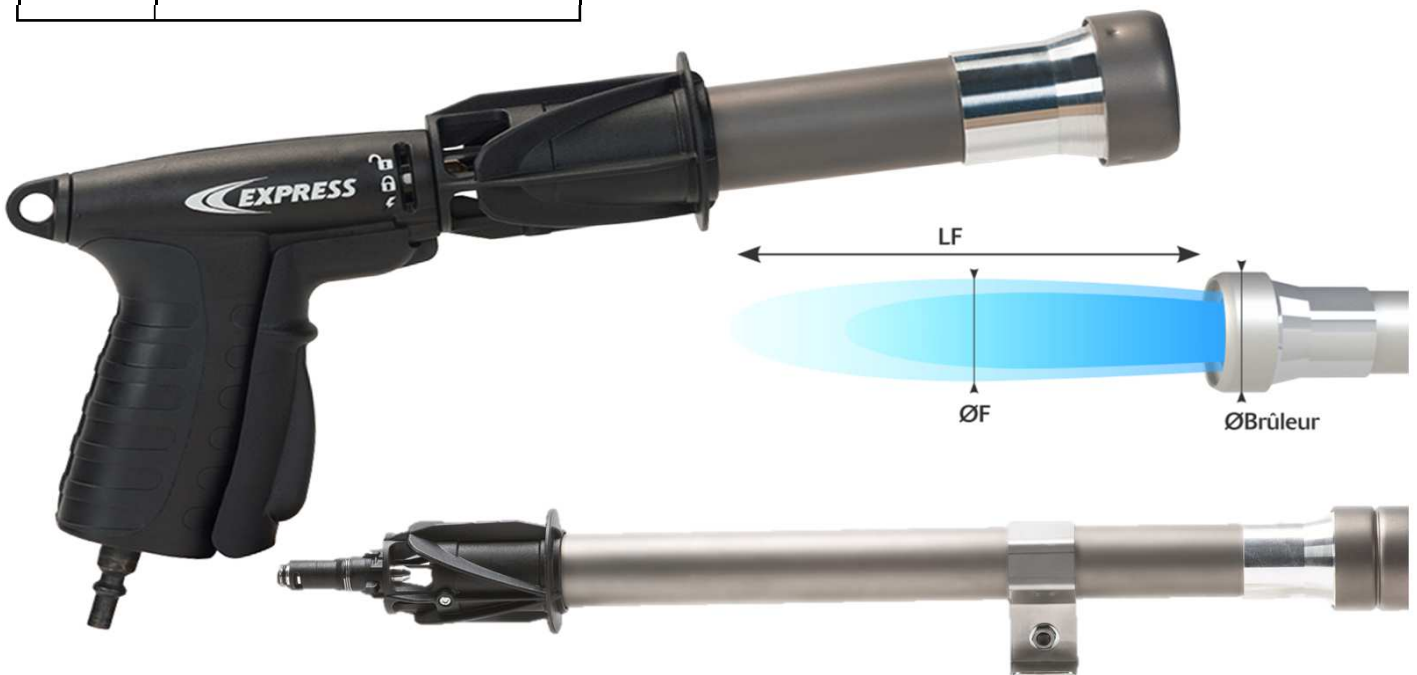

Cat. No.	Burner Ø (mm)	Burner weight (g)	Weight with handle (g)	@4 bar / 58 psi					
				Conso. (kg/h)	Power		Lf (mm)	Øf (mm)	Noise dBA
1030	35	160	476	2,58	30	102400	250	45	77
1070	41	178	494	5,22	70	238800	350	55	79
1090	50	254	570	6,77	90	308000	350	65	81
1150	50	325	641	11,8	160	546000	1100	65	81
1160	50	383	699	11,8	160	546000	1100	65	81

Functions

Synchronized lighting
Lightweight
Safety handle
One-hand flame power adjustment
Low sound level
4 powers, short and long torches

Spare part

Piezo + trigger Cat. No. 42305

Packaging

Cat. No.	Pack	Packaging
1027	Handle + 1030 + 1070	Suitcase
1029	Handle + 1070 + 1090	Suitcase
1045	Handle + 1150	Suitcase
1055	Handle + 1160	Suitcase
1030	30 kW torch	Alone
1070	70 kW torch	Alone
1090	90 kW torch	Alone
1150	160 kW torch	Alone
1160	160 kW curved torch	Alone
1001	1030 + scraper	Alone

IMPORTANT: Read instructions before use

GUILBERT EXPRESS reserves the right to change product characteristics without previous notice. Actual products may differ from photographs.

www.guilbert-express.net